

Ref:FU01-BV1UDF-2P  
 Ref:Initial  
 Page:1/2

## U TYPE DOUBLE FLANGED BUTTERFLY VALVE WITH PNEUMATIC ACUTATOR FU01-BV1UDF-2P



### APPLICATION

General Use: Water, sea water, gas, pressurized air, acids etc.

### CARACTERISTIQUES GENERALES

Design in accordance with NF EN 593. Tightness in both ways.  
 With low torque.

### CONSTRUCTION

NO.	PRATS	MATERIAL
1	BODY	CI / DI / SS / WCB
2	BUSHING	PTFE / BRONZE
3	SEAT	EPDM / NBR / VITON / SILICON etc
4	DISC	CF8 / CF8M / AL-BC / DUPLEX STEEL
5	STEM	SS416 / SS304 / SS316 etc
6	O-RING	NBR / EPDM
7	BUSHING	PTFE / BRONZE
8	BOLT	STAINLESS STEEL / GALVANIZED
9	PRESSURE RING	CARBON STEEL
10	BOLT	STAINLESS STEEL / GALVANIZED
11	FLAT WASHER	STAINLESS STEEL / GALVANIZED
12	PNEUMATIC ACUTATOR	ASSEMBLY



### DIMENSIONS

DN mm inch	A	B	L	PN10			PN16			ANSI 150		
				ΦD	N	M	ΦD	N	M	ΦD	N	M
50 2"	161	80	43	125	4	Φ18	125	4	Φ18	120.5	4	Φ19
65 2.5"	175	89	46	145	4	Φ18	145	4	Φ18	139.5	4	Φ19
80 3"	181	95	46	160	8	Φ18	160	8	Φ18	152.5	4	Φ19
100 4"	200	114	52	180	8	Φ18	180	8	Φ18	190.5	8	Φ19
125 5"	213	127	56	210	8	Φ18	210	8	Φ18	216	8	Φ22
150 6"	226	139	56	240	8	Φ23	240	8	Φ23	241.5	8	Φ22
200 8"	260	175	60	295	8	Φ23	295	12	Φ23	298.5	8	Φ22
250 10"	292	203	68	350	12	Φ23	355	12	Φ27	362	12	Φ25
300 12"	337	242	78	400	12	Φ23	410	12	Φ27	432	12	Φ25
350 14"	368	267	78	460	16	Φ23	470	16	Φ27	476	12	Φ29

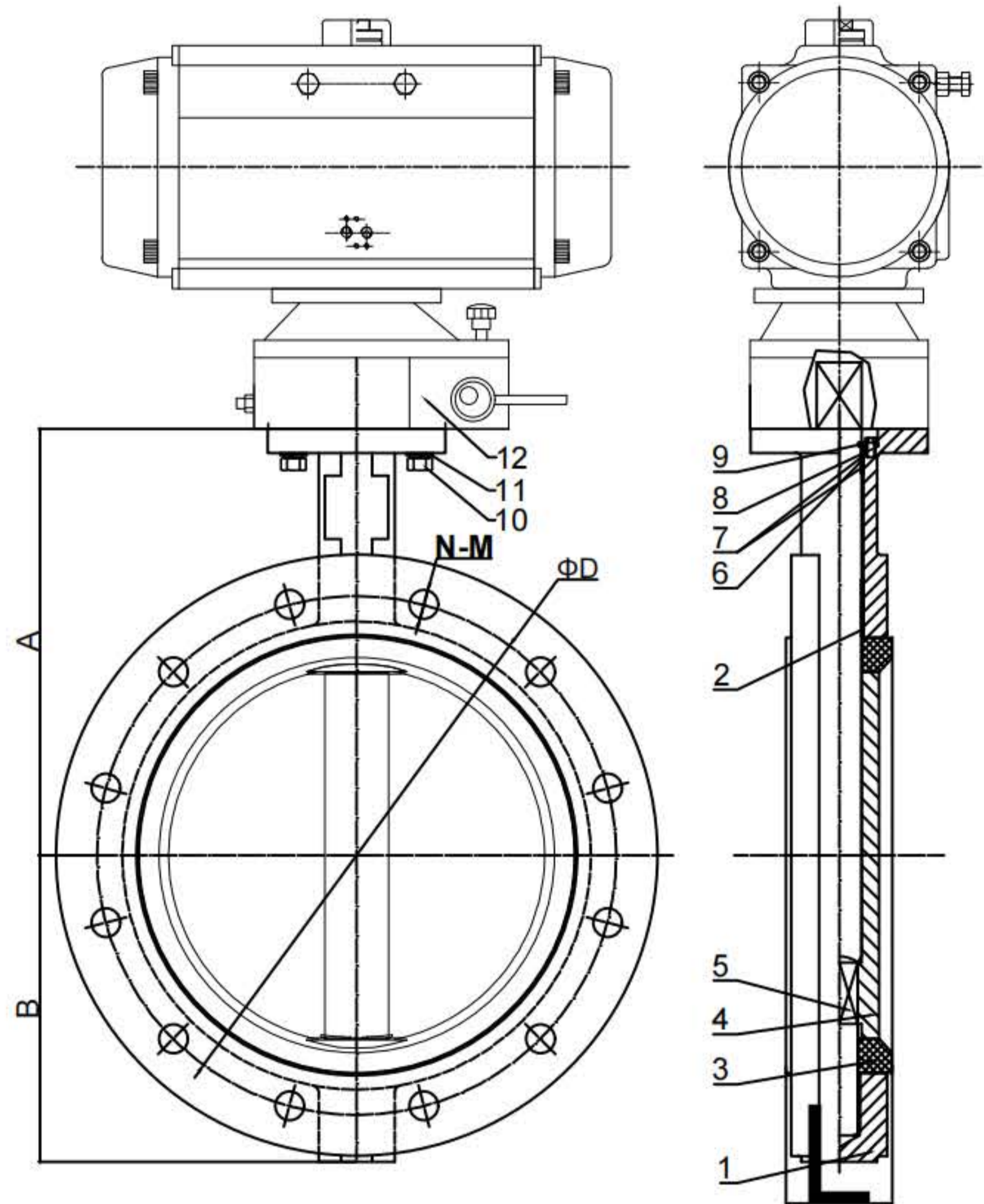

### WORKING CONDITIONS

Maximum Working Pressure: 16 bar.  
 Maximum Working Temperature table

Sleeve type in option	Maximum Temperature	Peak Temperature
EPDM	+4 °C ~ +110 °C	-20 °C ~ +130 °C
EPDM Blanc	+4 °C ~ +110 °C	-20 °C ~ +130 °C
CSM (Type Hypaion)	+4 °C ~ +80 °C	-20 °C ~ +110 °C
FPM (Type Viton)	-10 °C ~ +170 °C	-20 °C ~ +200 °C
Silione	-20 °C ~ +170 °C	-40 °C ~ +200 °C
Nitrile (NBR)	-10 °C ~ +80 °C	-20 °C ~ +90 °C

### STANDARDS

Manufacture according to the requirements of the European directive 2014/68/EU, modulate H Face to face according to standards NF EN558 SERIE 20. ISO5752, DIN3202. Mounting between flanges PN16  
 Body: 24bar  
 Seat: 17.6bar

Tianjin Fortis Valve Co., Ltd.  
 Fortis Valve-Guaizigou Industrial Zone, Xiaozhan Town, Jin nan District, Tianjin of China.  
 Tel: +86-22-88529757 Fax: +86-22-88818118  
 Email: info@fortisvalves.com Web: www.fortisvalves.com

Ref:FU01-BV1UDF-2P  
 Ref:Initial  
 Page:2/2

## U TYPE DOUBLE FLANGED BUTTERFLY VALVE WITH PNEUMATIC ACUTATOR FU01-BV1UDF-2P



### APPLICATION

General Use: Water, sea water, gas, pressurized air, acids etc.

### CARACTERISTIQUES GENERALES

Design in accordance with NF EN 593. Tightness in both ways.  
 With low torque.

### CONSTRUCTION

NO.	PRATS	MATERIAL
1	BOLT	STAINLESS STEEL / GALVANIZED
2	COVER	CI / DI / SS / WCB
3	O-RING	NBR / EPDM
4	BEARING	BEARING STEEL
5	BUSHING	PTFE / BRONZE
6	BODY	CI / DI / SS / WCB
7	SEAT	EPDM / NBR / VITON / SILICON etc
8	DISC	CF8 / CF8M / AL-BC / DUPLEX STEEL
9	STEM	SS416 / SS304 / SS316
10	O-RING	NBR / EPDM
11	BUSHING	PTFE / BRONZE
12	BOLT	STAINLESS STEEL / GALVANIZED
13	PRESSURE RING	CARBON STEEL
14	BOLT	STAINLESS STEEL / GALVANIZED
15	FLAT WASHER	STAINLESS STEEL / GALVANIZED
16	PNEUMATIC ACUTATOR	ASSEMBLY

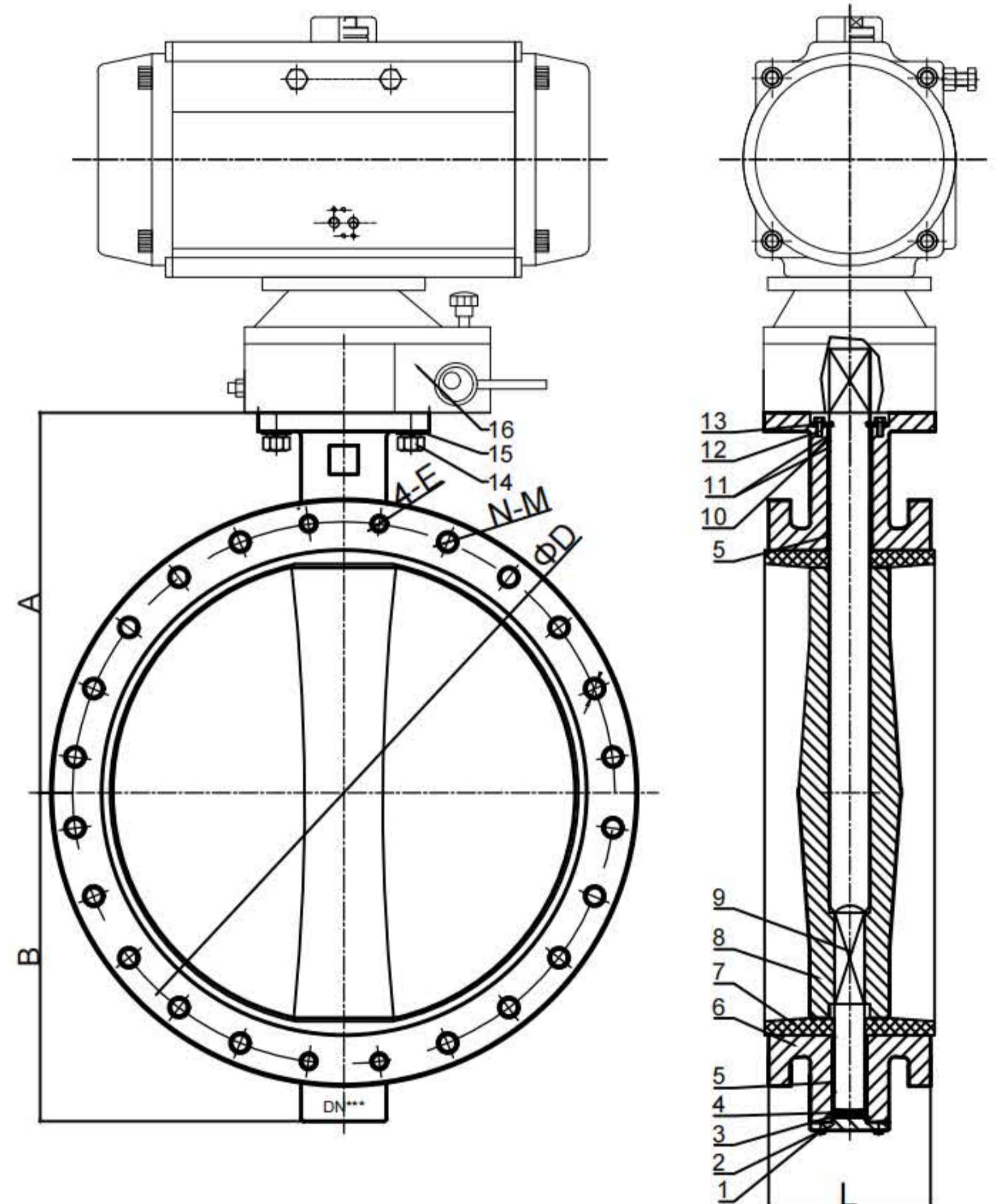

### DIMENSIONS

DN	A	B	L	PN10				PN16				ANSI 150				
				ΦD	N	M	E	ΦD	N	M	E	ΦD	N	M	E	
400	16"	400	297	102	515	16	Φ27	M24	525	16	Φ30	M27	539.5	16	Φ29	1"-8
450	18"	422	315	114	565	20	Φ27	M24	585	20	Φ30	M27	578	16	Φ32	1 1/8"-7
500	20"	480	348	127	620	20	Φ27	M24	650	20	Φ33	M30	635	20	Φ32	1 1/8"-7
600	24"	562	444	154	725	20	Φ30	M27	770	20	Φ36	M33	749.5	20	Φ35	1 1/4"-6
700	28"	629	512	165	840	24	Φ30	M27	840	24	Φ36	M33	863	28	Φ35	1 1/4"-6
800	32"	666	576	190	950	24	Φ33	M30	950	24	Φ39	M36	977.9	28	Φ41	1 1/2"-6
900	36"	722	635	203	1050	28	Φ33	M30	1050	28	Φ39	M36	1086	32	Φ41	1 1/2"-6
1000	40"	800	700	216	1160	28	Φ36	M33	1170	28	Φ42	M39	1200	36	Φ41	1 1/2"-6
1200	48"	941	844	254	1380	32	Φ39	M36	1390	32	Φ48	M45	1422.5	44	Φ41	1 1/2"-6

### WORKING CONDITIONS

Maximum Working Pressure: 16 bar.

Maximum Working Temperature table

Sleeve type in option	Maximum Temperature	Peak Temperature
EPDM	+4 °C ~ +110 °C	-20 °C ~ +130 °C
EPDM Blanc	+4 °C ~ +110 °C	-20 °C ~ +130 °C
CSM (Type Hypaion)	+4 °C ~ +80 °C	-20 °C ~ +110 °C
FPM (Type Viton)	-10 °C ~ +170 °C	-20 °C ~ +200 °C
Silicone	-20 °C ~ +170 °C	-40 °C ~ +200 °C
Nitrile (NBR)	-10 °C ~ +80 °C	-20 °C ~ +90 °C

### STANDARDS

Manufacture according to the requirements of the European directive 2014/68/EU, modulate H Face to face according to standards NF EN558 SERIE 20. ISO5752, DIN3202. Mounting between flanges PN16  
 Body: 24bar  
 Seat: 17.6bar

Tianjin Fortis Valve Co., Ltd.  
 Fortis Valve-Guaizigou Industrial Zone, Xiaozhan Town, Jin nan District, Tianjin of China.  
 Tel: +86-22-88529757  
 Email: info@fortisvalves.com  
 Fax: +86-22-88818118  
 Web: www.fortisvalves.com