

Ref:FU01-BV1UDF-1G
 Ref:Initial
 Page:1/2

U TYPE DOUBLE FLANGED BUTTERFLY VALVE WITH WORM GEAR FU01-BV1UDF-1G



APPLICATION

General Use: Water, sea water, gas, pressurized air, acids etc.

CARACTERISTIQUES GENERALES

Design in accordance with NF EN 593. Tightness in both ways.
 With low torque.

CONSTRUCTION

NO.	PRATS	MATERIAL
1	BODY	CI / DI / SS / WCB
2	BUSHING	PTFE / BRONZE
3	SEAT	EPDM / NBR / VITON / SILICON etc
4	DISC	CF8 / CF8M / AL-BC / DUPLEX STEEL
5	LOWER SHAFT	SS416 / SS304 / SS316
6	UPPER SHAFT	SS416 / SS304 / SS316
7	O-RING	NBR / EPDM
8	BUSHING	PTFE / BRONZE
9	BOLT	STAINLESS STEEL / GALVANIZED
10	PRESSURE RING	CARBON STEEL
11	BOLT	STAINLESS STEEL / GALVANIZED
12	FLAT WASHER	STAINLESS STEEL / GALVANIZED
13	WORM GEAR	ASSEMBLY

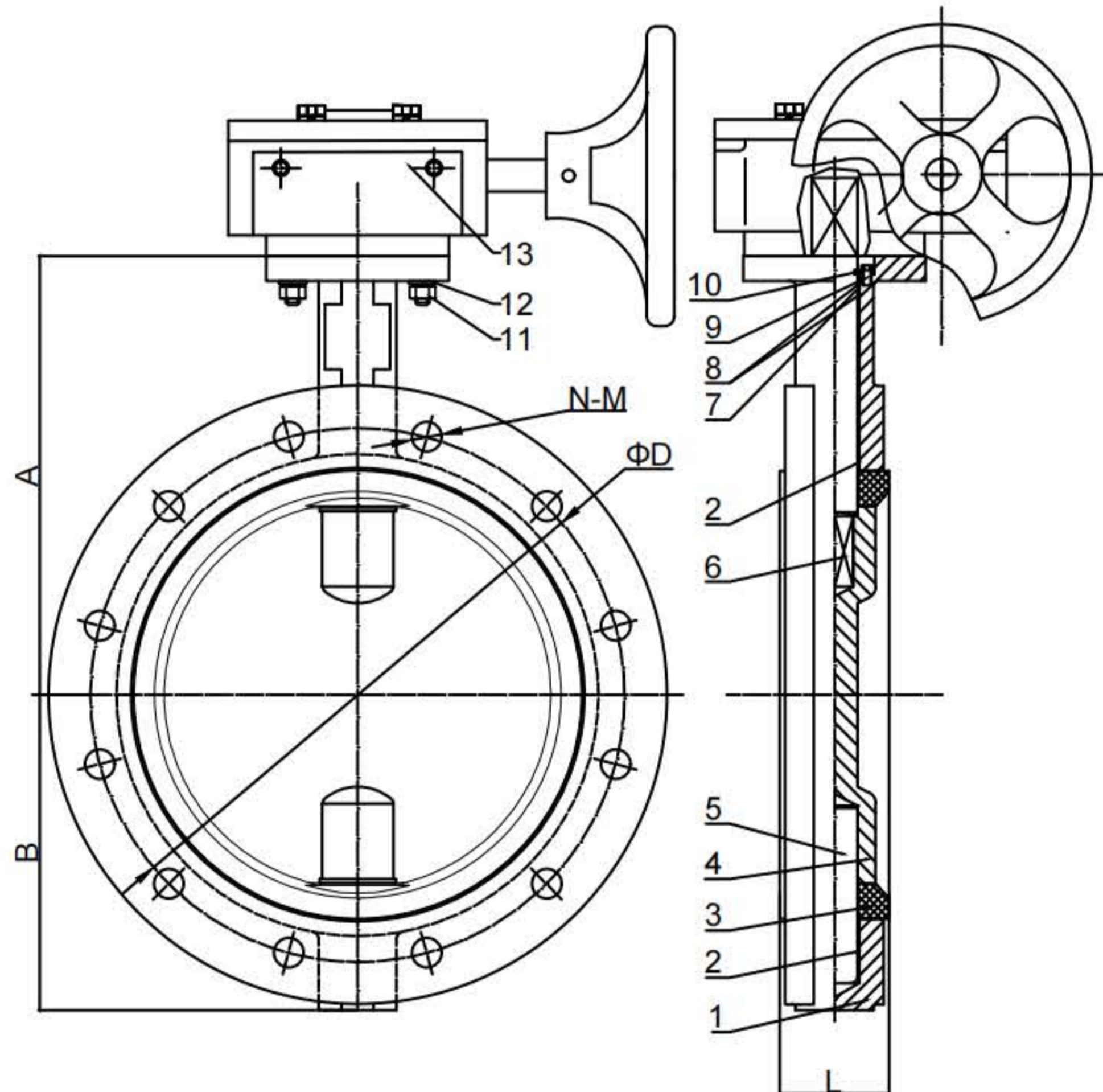

DIMENSIONS

DN	A	B	L	PN10			PN16			ANSI 150		
				ΦD	N	M	ΦD	N	M	ΦD	N	M
50	161	80	43	125	4	Φ18	125	4	Φ18	120.5	4	Φ19
65	175	89	46	145	4	Φ18	145	4	Φ18	139.5	4	Φ19
80	181	95	46	160	8	Φ18	160	8	Φ18	152.5	4	Φ19
100	200	114	52	180	8	Φ18	180	8	Φ18	190.5	8	Φ19
125	213	127	56	210	8	Φ18	210	8	Φ18	216	8	Φ22
150	226	139	56	240	8	Φ23	240	8	Φ23	241.5	8	Φ22
200	260	175	60	295	8	Φ23	295	12	Φ23	298.5	8	Φ22
250	292	203	68	350	12	Φ23	355	12	Φ27	362	12	Φ25
300	337	242	78	400	12	Φ23	410	12	Φ27	432	12	Φ25
350	368	267	78	460	16	Φ23	470	16	Φ27	476	12	Φ29

WORKING CONDITIONS

Maximum Working Pressure: 16 bar.
 Maximum Working Temperature table

Sleeve type in option	Maximum Temperature	Peak Temperature
EPDM	+4°C~+110°C	-20°C~+130°C
EPDM Blanc	+4°C~+110°C	-20°C~+130°C
C5M(Type Hypalon)	+4°C~+80°C	-20°C~+110°C
FPM (Type Viton)	-10°C~+170°C	-20°C~+200°C
Silicone	-20°C~+170°C	-40°C~+200°C
Nitrile (NBR)	-10°C~+80°C	-20°C~+90°C

STANDARDS

Manufacture according to the requirements of the European directive 2014/68/EU, modulate H Face to face according to standards NF EN558 SERIE 20. ISO5752, DIN3202. Mounting between flanges PN16
 Body: 24bar
 Seat: 17.6bar

Tianjin Fortis Valve Co., Ltd.
 Fortis Valve-Guaizigou Industrial Zone, Xiaozhan Town, Jin nan District, Tianjin of China.
 Tel: +86-22-88529757 Fax: +86-22-88818118
 Email: info@fortisvalve.com s.com Web: www.fortisvalve.com s.com

Ref:FU01-BV1UDF-1G
 Ref:Initial
 Page:2/2

U TYPE DOUBLE FLANGED BUTTERFLY VALVE WITH WORM GEAR FU01-BV1UDF-1G



APPLICATION

General Use: Water, sea water, gas, pressurized air, acids etc.

CARACTERISTIQUES GENERALES

Design in accordance with NF EN 593. Tightness in both ways.
 With low torque.

CONSTRUCTION

NO.	PRATS	MATERIAL
1	BOLT	STAINLESS STEEL / GALVANIZED
2	COVER	CI / DI / SS / WCB
3	O-RING	NBR / EPDM
4	BEARING	BEARING STEEL
5	BUSHING	PTFE / BRONZE
6	BODY	CI / DI / SS / WCB
7	SEAT	EPDM / NBR / VITON / SILICON etc
8	DISC	CF8 / CF8M / AL-BC / DUPLEX STEEL
9	LOWER SHAFT	SS416 / SS304 / SS316
10	UPPER SHAFT	SS416 / SS304 / SS316
11	O-RING	NBR / EPDM
12	BUSHING	PTFE / BRONZE
13	BOLT	STAINLESS STEEL / GALVANIZED
14	PRESSURE RING	CARBON STEEL
15	BOLT	STAINLESS STEEL / GALVANIZED
16	FLAT WAHSER	STAINLESS STEEL / GALVANIZED
17	WORM GEAR	ASSEMBLY

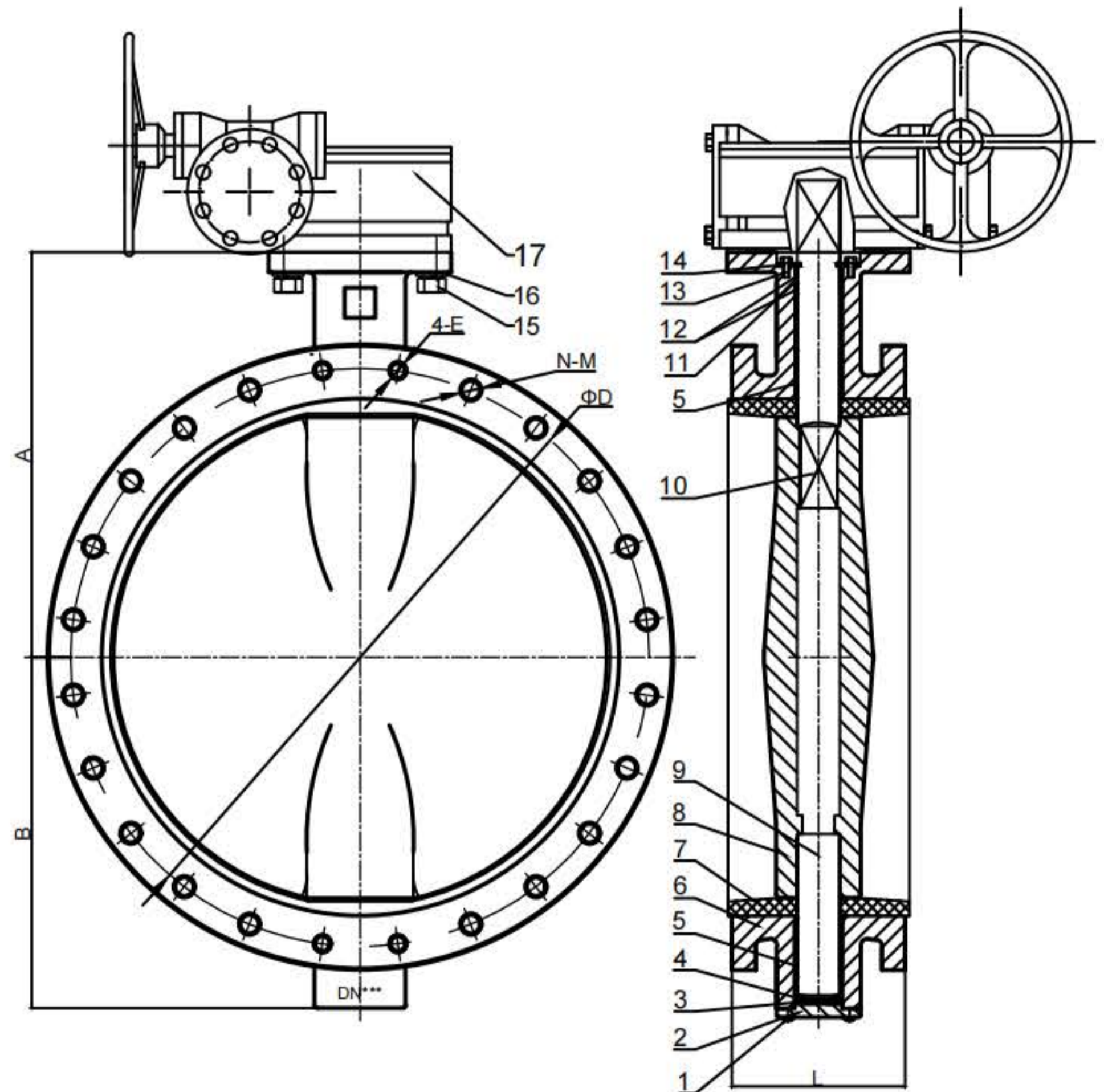

DIMENSIONS

DN	A	B	L	PN10			PN16			ANSI 150						
				ΦD	N	M	E	ΦD	N	M	E	ΦD	N	M	E	
400	16"	400	297	102	515	16	Φ27	M24	525	16	Φ30	M27	539.5	16	Φ29	1"-8
450	18"	422	315	114	565	20	Φ27	M24	585	20	Φ30	M27	578	16	Φ32	1 1/8"-7
500	20"	480	348	127	620	20	Φ27	M24	650	20	Φ33	M30	635	20	Φ32	1 1/8"-7
600	24"	562	444	154	725	20	Φ30	M27	770	20	Φ36	M33	749.5	20	Φ35	1 1/4"-6
700	28"	629	512	165	840	24	Φ30	M27	840	24	Φ36	M33	863	28	Φ35	1 1/4"-6
800	32"	666	576	190	950	24	Φ33	M30	950	24	Φ39	M36	977.9	28	Φ41	1 1/2"-6
900	36"	722	635	203	1050	28	Φ33	M30	1050	28	Φ39	M36	1086	32	Φ41	1 1/2"-6
1000	40"	800	700	216	1160	28	Φ36	M33	1170	28	Φ42	M39	1200	36	Φ41	1 1/2"-6
1200	48"	941	844	254	1380	32	Φ39	M36	1390	32	Φ48	M45	1422.5	44	Φ41	1 1/2"-6

WORKING CONDITIONS

Maximum Working Pressure: 16 bar.

Maximum Working Temperature table

Sleeve type in option	Maximum Temperature	Peak Temperature
EPDM	+4 °C ~ +110 °C	-20 °C ~ +130 °C
EPDM Blanc	+4 °C ~ +110 °C	-20 °C ~ +130 °C
CSM (Type Hypaion)	+4 °C ~ +80 °C	-20 °C ~ +110 °C
FPM (Type Viton)	-10 °C ~ +170 °C	-20 °C ~ +200 °C
Silicone	-20 °C ~ +170 °C	-40 °C ~ +200 °C
Nitrile (NBR)	-10 °C ~ +80 °C	-20 °C ~ +90 °C

STANDARDS

Manufacture according to the requirements of the European directive 2014/68/EU, modulate H Face to face according to standards NF EN558 SERIE 20. ISO5752, DIN3202. Mounting between flanges PN16
 Body: 24bar
 Seat: 17.6bar

Tianjin Fortis Valve Co., Ltd.
 Fortis Valve-Guaizigou Industrial Zone, Xiaozhan Town, Jin nan District, Tianjin of China.
 Tel: +86-22-88529757 Fax: +86-22-88818118
 Email: info@fortisvalves.com Web: www.fortisvalves.com